



NORTH AMERICAN STEEL

ADVANCED STORAGE SOLUTIONS

RACKING SYSTEMS



ROLLFORMED * STRUCTURAL * HYBRID

Selective - Double Deep - Very Narrow Aisle - Storage Platform
Drive In - Drive Thru - Push Back - Carton Flow - Pallet Flow
Cantilever - Mezzanine & Catwalks - Pick Rack - Retail Fixture Rack

WWW.NORTHAMERICANSTEEL.CA

Selective Pallet Racking



NAS PALLET RACKING provides the widest range of flexibility for your pallet and heavy - duty bulk storage needs. Stocking vertically and horizontally maximizes available space without crushing inventory with the ability to access each individual load. Only two basic components, beams and frames, are required for basic installations and can be installed without tools, adjusting easily to your specific needs. A variety of sizes are available for load requirements up to 100,000 Lbs.

Features

- 100% Selectivity
- Easy picking lower levels
- Good storage density
- Easily relocated

Applications

- Warehouses & Logistics
- Manufacturing Plants
- Food & Grocery Distribution
- Petroleum, Chemical & Pharmaceutical Plants

Double Deep Selective Racking



NAS DOUBLE DEEP RACKING features back to back pallet storage two pallets deep. Ideal for increased storage density requirements where lift trucks have extended reach capability. Double Deep selective rack can be easily converted from single Selective rack.

Features

- 50% Selectivity
- Minimal increased lift truck costs
- Increased Storage Capacity
- Easily relocated

Applications

- Warehouses & Logistics
- Manufacturing Plants
- Food & Grocery Distribution
- Petroleum, Chemical & Pharmaceutical Plants

Retail Fixture Rack



RETAIL RACK gives retailers an upscale warehouse look while displaying more SKU's plus overhead stock replenishment storage. More and more retailers are converting to the warehouse style superstores. The same marketing advantages can be achieved in any size store. Specialized components are available to display anything from tubs to hand tools to garden equipment. Pallet Rack can be installed over or integrated into store fixture shelving.

Features

- Less expensive than traditional store fixtures
- Very versatile for displaying merchandise
- Supports pegboard, wire baskets, metal or wood shelves and all types of vendor displays

Applications

- Building Supply and Hardware Retailers
- Large Outlet Stores
- Small and Mid Sized Retailers who require additional merchandising space

Pick Rack



Pick Rack is ideal for hand case picking. Rack frames and beams are designed to meet your specific product size and weights. Full pallets can be stored above with independent access for lift trucks. Pick Rack boltless connections facilitate quick and simple assembly and adjustability. Step beams provide shelf options of roof deck, metal drop-in panels, cut lumber or wire mesh decks.

Features

- Optimum Combined Selectivity and Bulk Storage Capacity
- Wide Variety of accessories to accommodate special storage needs safer, cleaner and more convenient storage

Applications

- Banker Box Record Storage
- Hospital Records Storage
- Automotive Parts Distributors
- Industrial Supply Distributors
- Plumbing/Electrical Distributors

STEPBEAM

A one-piece multi-purpose beam with a rolled-instep, pierced to accommodate safety bars, shelf supports and other unique accessories. Full 1 7/8" top face for superior pallet support.

Our one-piece rollformed tube provides strength and safety. The seam of our beam is at the rear under the step, preventing accidental forklift or pallet "hooking".

Our 3" deep bracket allows us to weld our beams front and rear.

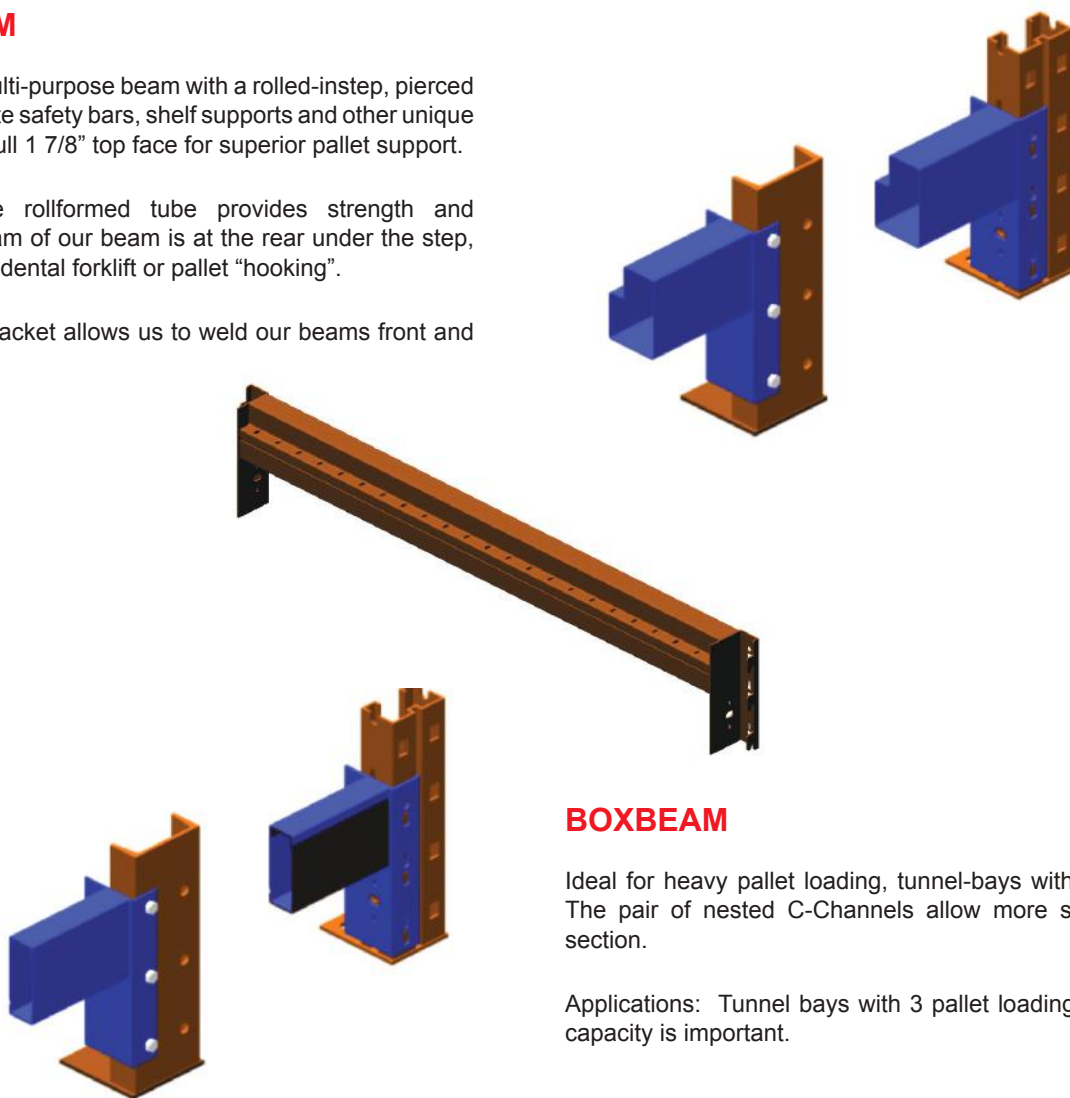

BOXBEAM

Ideal for heavy pallet loading, tunnel-bays with 3 pallet loading. The pair of nested C-Channels allow more steel in a smaller section.

Applications: Tunnel bays with 3 pallet loading where improved capacity is important.

STRUCTURAL BEAMS

C-Channel Structural Beams

C-Channel beams are recommended for heavy traffic and high abuse areas, (i.e. front beams on push back and flow rack). The structural shape places the most amount of steel on the face and face corners to prevent damage at impact. To obtain the full rated capacity C-Channels require tie bars to prevent rotation.

Wide Flange Structural Beams

I-Beams offer the same features as the C-Channel beams but have greater load capacity over longer spans.

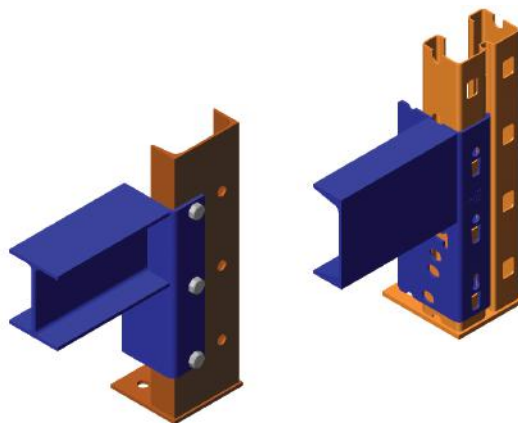

- ! ALL BEAMS are available for both structural and rollformed endframes. The only change is the type of connector used to attach the beam to the column. All beams have a safety factor of 1.67
- △ STANDARD SAFETY CLIPS, supplied with each beam, resist accidental uplift of up to 2,000 lbs. per beam. Attachable self-locking spring clips are available. Bolts may also be used for special applications.
- △ PAINT FINISH: All NAS rack is powder coated over properly cleaned and iron phosphate etched surface. Oven baked at proper temperature/time ratio to produce a durable scratch resistant finish.

ROLLFORMED ENDFRAMES



EF 214
Endframe



EF 313
Endframe

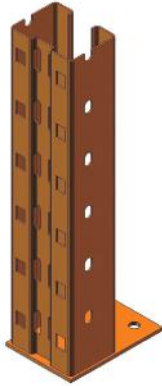

EF413
Column



Capacities from 25,000 to 100,000 lbs, with a safety factor of 2.0.

Our 2", 3" and 4" depth 14, 13 & 12 gauge post with 10 vertical bends provides greater impact, shock load and overload resistance.

The unique rear returns on our posts improve rigidity and strength without wasting width of shelf space while creating a safer section.

Our tubular bracing is stronger than simple channels and less likely to be damaged or to cause injury. The horizontal bracing is welded at both ends against the front and rear endframe column. This design creates a stronger section to resist accidental forklift impact.

Our 6-point wrap-around beam connector at both ends supports each beam at 12 points on the endframe. The beam connector automatically squares the beam to the frame for ease of installation and rigidity.

ENDFRAME OPTIONS

Double Post

A double post increases the capacity and transfers the axial load to the second post if the front post is damaged.

Heavy Duty Lower Brace

Heavy duty lower braces transfer frontal impact energy to the back post of the end frame.

Angle Deflector with/without cap

This angle deflects the lift truck forks or pallets away from the endframe. It is available with or without a cap. The benefit of a cap is to stop debris from accumulating in the deflector. Note: 1" clip-on post protectors are also available.

Structural Column Insert

With this design a structural C-Channel is inserted inside the column and welded in place (usually to the first beam level). This increases the impact resistance of the column as the energy from an impact is transferred to the structural column.

Cant-Leg Frame

Angles the front aisle post away from the aisle to prevent accidental damage from pallet entry on the lower level.

Recessed Frame

The front aisle post is recessed to allow greater aisle clearance for lift truck turning and pallet entry.



Double Posted
Endframe



Heavy Duty
Lower Brace



Angle Deflector
without a cap



Structural Column insert
(cut away view)



Cant-Leg Frame



Recessed Frame

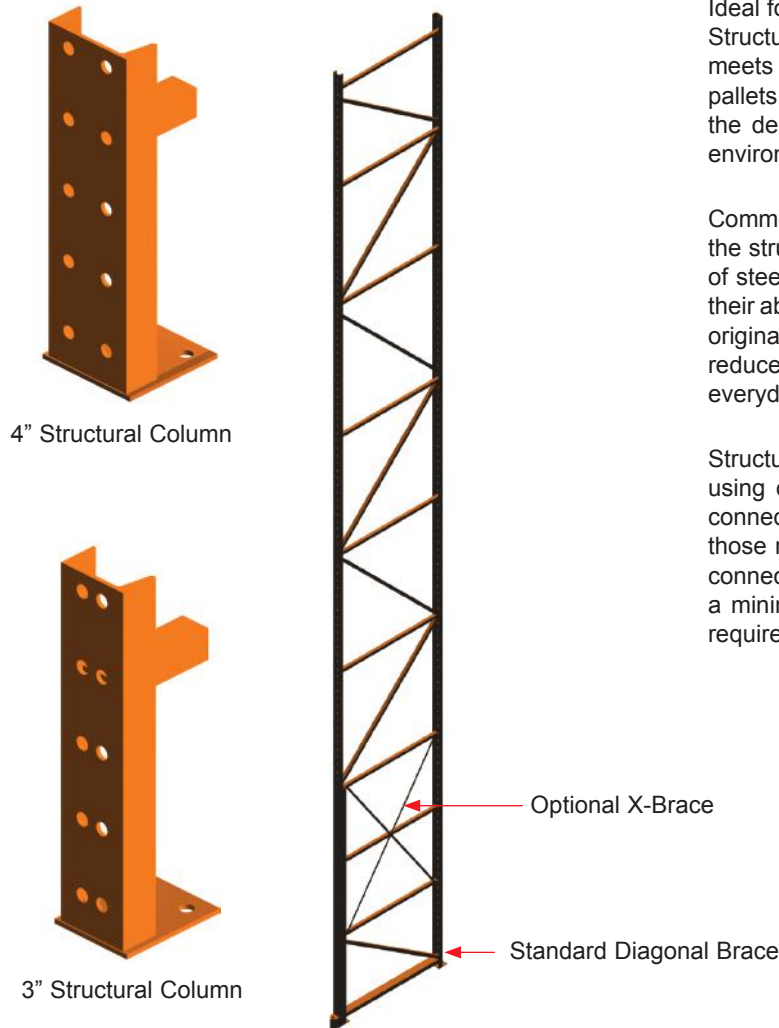

Ideal for high rise systems, heavy traffic and high abuse areas. Structural rack is available in a variety of column sizes and meets the required frame loads of today's higher and heavier pallets. Structural rack is the most cost effective product to meet the demands of efficient storage use in a potentially abusive environment.

Common lift truck damage is reduced due to the advantage of the structural shape of the column by placing the most amount of steel at the front face corners. Load carrying members lose their ability to support the stated loads when deformed from their original shapes. The extra strength provided by structural rack reduces this risk. Structural rack is less likely to be deformed by everyday fork truck abuse.

Structural sections are thick enough to allow repairs to be made using ordinary cutting and welding equipment. The structural connector has the same upload and download capacity for those rugged applications. Connectors allow for 2, 3, or 4 bolt connection. To meet heavy loads and seismic conditions, a minimum of four 1/2" grade 5 nuts and bolts per beam are required.

ENDFRAME OPTIONS

Double Post

A Double Post increases the capacity and transfers the axial load to the second post if the front post is damaged.

Heavy Duty Lower Brace

Heavy duty lower braces transfer frontal impact energy to the back post of the end frame.

Angle Deflector with/without cap

An angle deflector is welded to the endframe. This angle deflects the lift truck forks away from the endframe. It is available with or without a cap. The benefit of a cap is to stop debris from accumulating in the deflector.

Recessed Frame

The front aisle post is recessed to allow greater aisle clearance for lift truck turning and pallet entry.

Cant-Leg Frame

Angles the front aisle post away from the aisle to prevent accidental damage from pallet entry on the lower level.

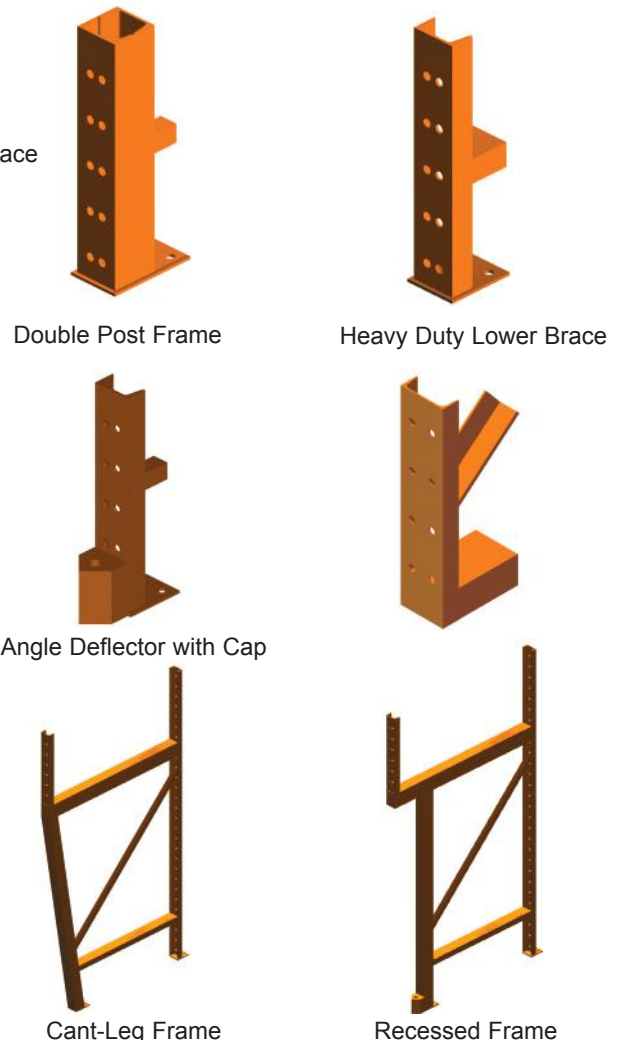

ACCESSORIES - SELECTIVE RACK

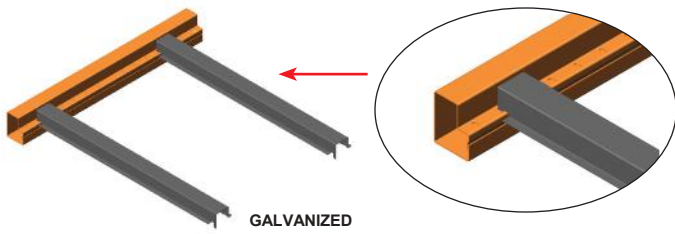

GALVANIZED

SAFETY BARS – MEDIUM OR HEAVY DUTY: Safety bars sit flush in pre-slotted step beams to stop improperly placed pallets from falling between beams. They prevent spreading on extra wide racks under heavy loads. Two safety bars per pallet position are recommended on installations over 16 ft.

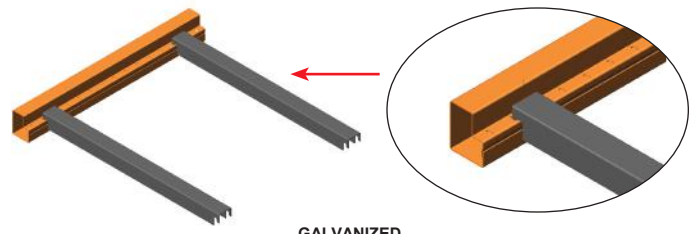

GALVANIZED

COMBO SHELF SUPPORTS & SAFETY BARS FOR STEP BEAMS: This shelf support has all the same features as the medium duty safety bars except it sits 7/8" below the top of the beam to provide a flush surface, when plywood, particle board or other sheet material is used. Minimum four per 96" shelf.



GALVANIZED – 2 BOLTS

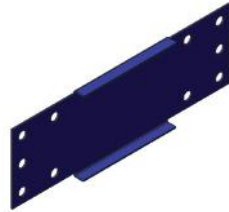

PAINTED – UNIVERSAL TYPE - 4-BOLTS

ROW SPACERS: Are used for back-to-back rows to tie the end frames together for stability and consistent spacing. They will also support in-rack sprinkler systems. Mandatory installation: 1 for 10 ft. high; 2 for 22 ft. high; 3 for 26 ft. high, etc.

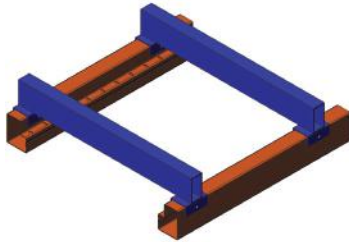

FORK ENTRY BARS

Support non-palletized loads, e.g. wallboard, plywood and metal sheets.

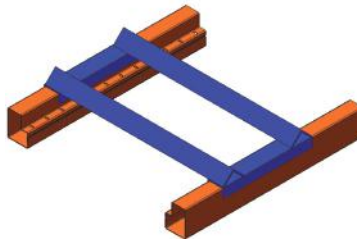

DRUM CRADLES

Designed to adapt racking to hold round objects. The unit is completely welded and fits securely on NAS Step Beams.

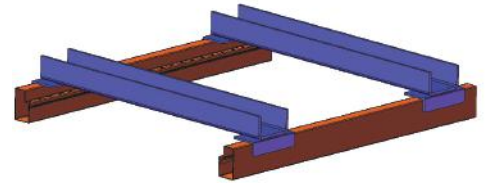

SKID CHANNEL

Adapt rack to the storage of semi-live and stationary skids.

RACK SHELVING SYSTEMS FOR STEP BEAMS:



WIRE MESH DECKS

Ease of installation, high strength, galvanized corrosion resistant finish. Ideal where sprinkler systems are required meeting specifications of 50% clear opening for waterflow.



SHELF SUPPORT

Choose from steel shelf support or 1"x6" lumber to support wood shelves. A variety of materials, plywood, particle board or finished board can be used for the shelving.



DROP-IN PANELS

Galvanized steel panels providing a smooth surface. Available in 6" or 9" standard width.



CUT LUMBER

An inexpensive shelving for NAS step beams. Standard 2"x4", 2"x6", and 2"x8" lumber fits flush into step beam.

POST PROTECTORS

Post protectors provide added protection in high traffic areas. The angle helps to deflect rather than to absorb direct frontal impacts and reduces the possibility of rack damage.

WELDED-ON PROTECTORS

Factory welded to the front of the upright is the most economical protection. **Available only on new installations.**

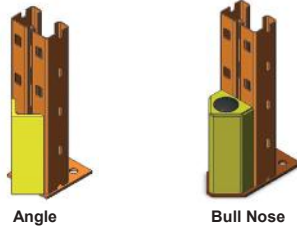

CLIP-ON PROTECTORS

Clip-on to the front face of rack frame. **The longer (15") style is designed for use with base plate beams.**

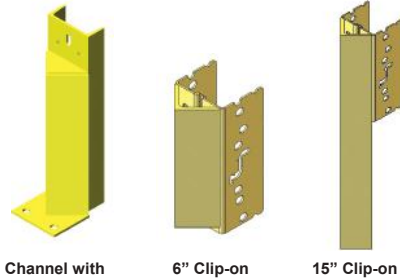

FLOOR MOUNTED PROTECTORS

These are the most common type of stand alone protectors.

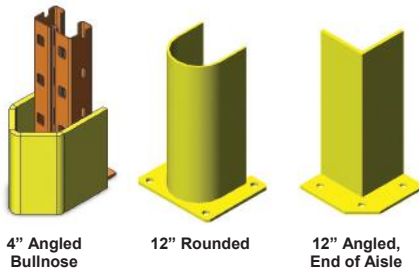

END OF AISLE GUARDS

TAPERED FLOOR MOUNT

Providing protection for end of row frames against lift truck damage. Adds a neat finished appearance.

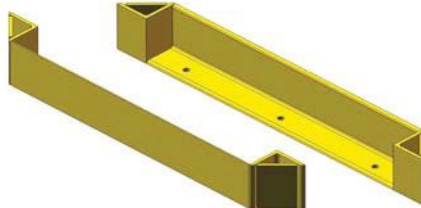

RAISED

This raised aisle guard is preferred where cleaning under the guard is a sanitary necessity.

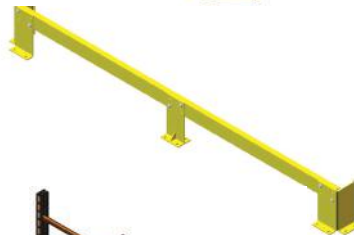

FRAME MOUNTED

Protect frames and braces from fork lift truck impact above floor level.

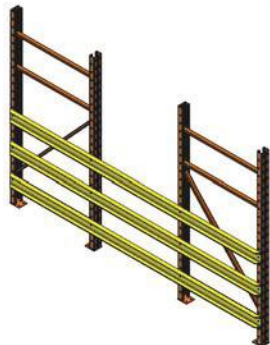

RACK FRAME REPAIR KITS

Are a simple and cost effective solution to repair lower level frame damage. Manufactured from heavy steel with **abuse resistant horizontal braces** the repair results in **stronger than original** frames with higher tolerance to impact damage. North American Steel manufactures these repair kits for Straight, Cantilever and Recessed style frames, being powder coated in "safety yellow" for better visibility by lift truck drivers.



STRAIGHT LEG

CANT LEG

RECESSED LEG

FRAME REPAIR KIT

Front frame is cut and the reinforcement added in and bolted at front and rear to the existing posts.

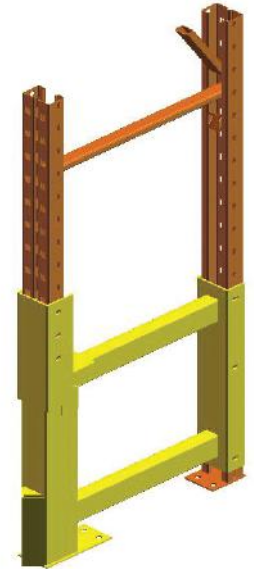

FRONT LEG BOOT

Replaces damaged FRONT post below lower horizontal brace.

Front reinforcement wraps around front of the frame, protecting it and absorbing impact.

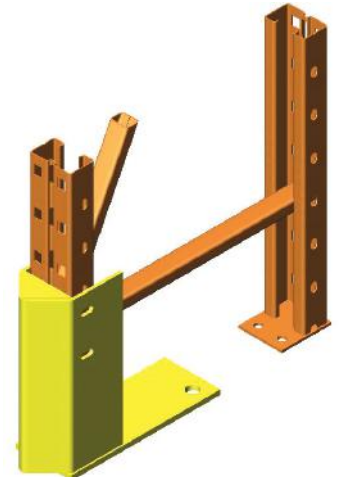

DRIVE IN/THRU RACKING

Front to back rails replace standard beams to support pallets. Lift trucks access pallets by driving into lanes from one or both ends. In a Drive-In system, pallet loading and retrieval is from the same aisle and is used where last-in first-out (LIFO) principle is acceptable. Maximizes storage capacity against a wall. In a Drive-Thru system, pallet loading and retrieval can be from aisles at either end and is used where first-in first-out (FIFO) principle is desirable.

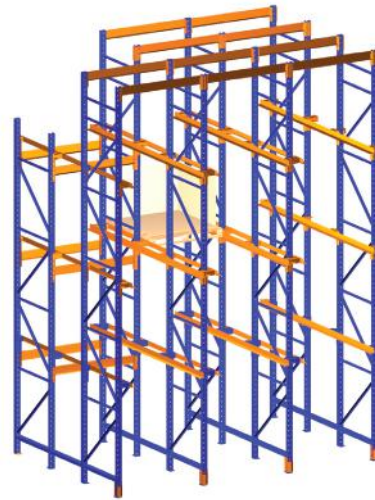

Lowest Cost High Density Storage

System is designed for storage of a large number of pallets of the same product.

Fewer Aisles

Multiple pallets deep allow 70% higher storage density than selective rack.

Selectivity

Based on one designated product per tunnel.

Rotation of Product

Drive - In is ideal for SLOWER moving, single designated products per tunnel.

Drive - Thru is ideal for FASTER moving, single designated products per tunnel.

Ideal for Cold Storage

High density storage with no moving parts reduces capital and operating costs of refrigeration.

Uses Less Vertical Height

With Pallets stored on angle rails, vertical space occupied by beams can now be used for product and in some cases may allow an extra pallet level.

MORE STORAGE IN THE SAME SPACE

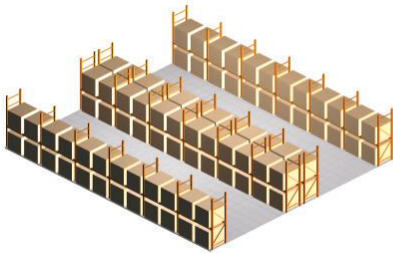

Standard Conventional Rack

Conventional Pallet Rack with 48 pallet locations per zone

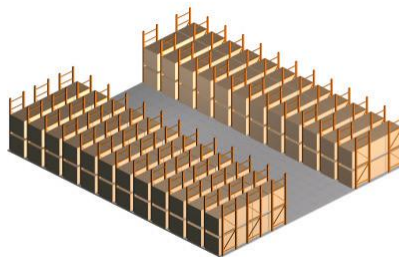

Same Floor Space

Drive - In rack with same floor space holding 84 pallet positions per zone increasing storage space by 75%.



Same Storage in less space

Drive - In rack showing same pallet locations as conventional Rack using only 70% of the floor space.

LOAD RAILS

Angle Rails

support the pallet being stored and act as pallet guides while loading and removing pallets. This type of rail provides the minimum vertical clearance. (Less than standard selective racking).

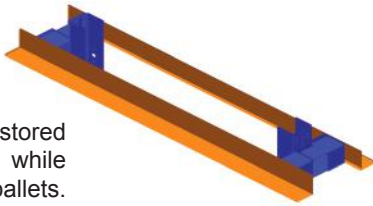

Channel Rails

Channel Rails allow for varying pallet widths in the same bay. These rails can provide higher capacities.

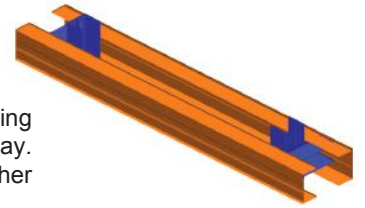

GUIDE RAILS

Guide Floor Rails

are mounted to the floor independent of the frames and guide the lower pallet or straddle truck through the tunnel bay.

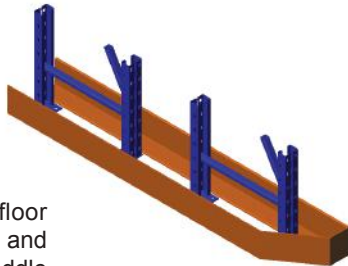

Channel Rub Rails

are mounted just above the floor between frame posts and provide protection from impact damage by lift trucks and pallets.

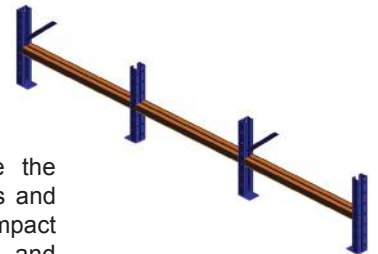

SUPPORT ARMS

Left/Right Hand Common Arms

Feature 12 point positive connection to each column and rail to resist accidental disengagement. The length of the arm allows for product overhang and lift truck clearance.



PALLET STOPS

Rail Angle Stops

are welded to angle rails to prevent pallets from exceeding end of rail.

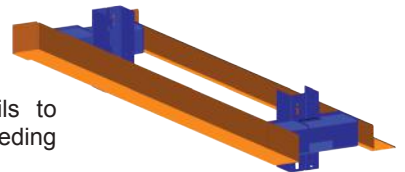

Endframe Back Stops

Prevent pallets from exceeding end of rail and add lateral stability to each bay.

Beam Back Stops

provide additional stability and prevent accidental pallet damage to the building.

SYSTEM DESIGN



NAS will engineer and design the most efficient system based on the specific parameters of each application.



Since Drive-In/Thru racks see more traffic than most other storage systems, NAS's superior rack components can be custom designed for your application for added impact resistance and safety.

PUSH BACK RACKING

Push-Back Rack is a means of high density storage with good selectivity. Multiple Pallets are stored on a gravity-fed cart system, allowing retrieval of the pallets from the face of the rack. The carts support the pallets allowing for some variation in pallet sizes. Systems are custom designed as 2, 3, 4 or 5 pallets deep and are normally used against a wall or in back - to - back rows.

Push Back vs Drive In

Features	Push Back	Drive In
Utilization	High	Low
Up To Double the Storage	Yes	Yes
Pick Rate	High	Low
Number of Pick Faces per Bay	4-8	1



Push Back Cart with a Mesh Deck Insert

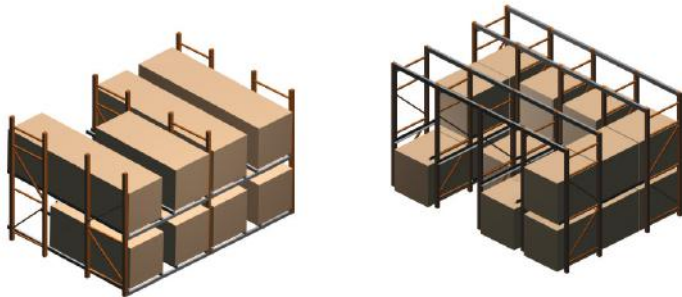

Often existing Selective Rack can be retrofitted into Push-Back Systems

Ideal for Automatic Retrieval Systems - incorporating into Pick-Towers and Rack Supported Buildings

More storage area - with fewer aisles

Reduced restocking - multiple pallets deep allow longer restock cycle

Storage density of Drive-In Rack with the selectivity of Flow Rack. One pallet rack face for each product, not a total bay for each product

No special forklifts required

Faster retrieval time - lift trucks don't have to travel down Drive-In tunnels or secondary aisles

Less damage to product and rack. Only front pallet and rack frame is accessible to lift truck impact

Lasting durability - with added reinforcement to exposed front frames

Accommodate a variety of pallet sizes and types - with full frame mesh decks

Push Back Carts/Trolleys

Push Back Low Profile Structural Carts have:

- High impact resistant - structural members
- Intermediate rail supports for different pallet sizes and types
- Large diameter wheels assure smooth rolling
- Low temperature sealed bearings for harsh environments
- Rubber bumper-stops protect load impact and reduce noise

Low Profile Carts



Every Installation Custom Designed

- Uses standard rollformed or structural frames
- Only the front column sees all the traffic and requires reinforcement kits
- Accepts all types of NAS beams - Step, Box or Structural
- Accommodates all pallet weights and sizes
- No specialized lift trucks required

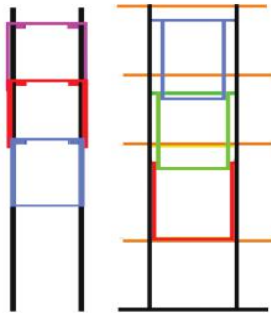

4 Deep Push Back Carts

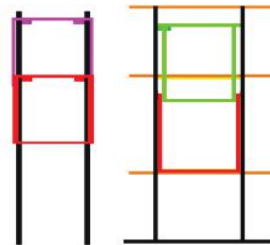

3 Deep Push Back Carts

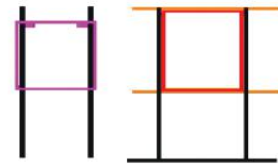

2 Deep Push Back Carts



Example Showing Push Back Racking Over Carton Flow Pick Aisle

CARTON FLOW RACKING

Carton Flow Rack is a stationary, rack-supported structure with multiple shelf levels. Each shelf level has roller rails and dividers suitable for cartons and small containers. The shelf levels are slightly declined to allow the product to flow (roll) from the loading side to the unloading side.



Plastic Rail Tracks
Ideal for small light boxes. Rails and dividers adjust easily for variety of merchandise.

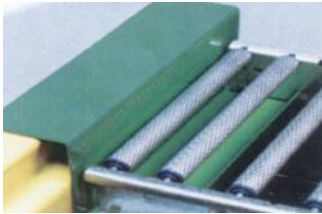

Full Width Mini-Rollers
Ideal for larger heavier boxes and longer spans. Separate conveyor for each box. Typically, tracks drop into existing racking for picking on floor level and standard pallet storage on higher levels.

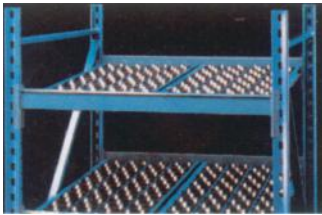

Skate Wheel Beds
Ideal for heavy loads. The skate wheels allow for a variety of product sizes without adjustment.



Pick Tray
Maximizes view and access of items to be picked.



Staggered Levels
Staggered shelves allow for easier access to products picked along with better product visibility.



Ideal for Distribution Centers
Where "high activity" open and full carton picking is required for quick and efficient "multi-lane order" operations.

Lower Labour Cost
Items are "up front", less walking and movement. The retrieval time decreases significantly.

Picking Accuracy Increases
Each product has its own designated flow lane.

FIFO Stock Rotation Guaranteed
Always First-In, First-Out.

Ultimate Adjustability
Clip-on shelves adjust for varying box heights. Snap in rollers and dividers are available for varying box widths.

Flexible Construction
Allows carton flow shelves to be supported by a variety of frame structures depending on the requirements today and changes required in the future.

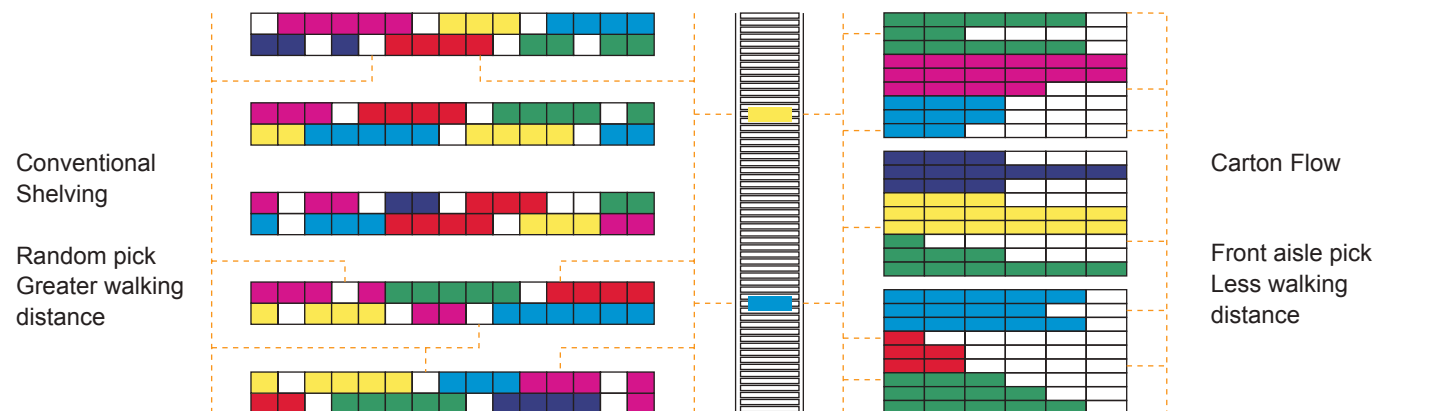

PALLET FLOW RACKING

A stationary rack structure and dynamic roller mechanism suitable for standardized pallets or larger containers. Gravity flow pallet movement from loading face to discharge face. Typical systems are up to 5 pallet lanes high and up to 20 pallets deep. Flow rack has capacities up to 4000 lbs per pallet.

Conventional Selective Rack

Skid locations 108

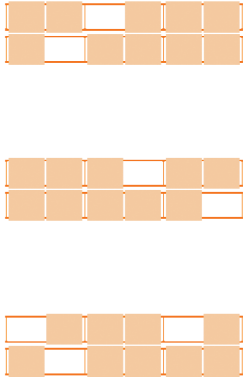

Pallet Flow Rack

Skid locations 162

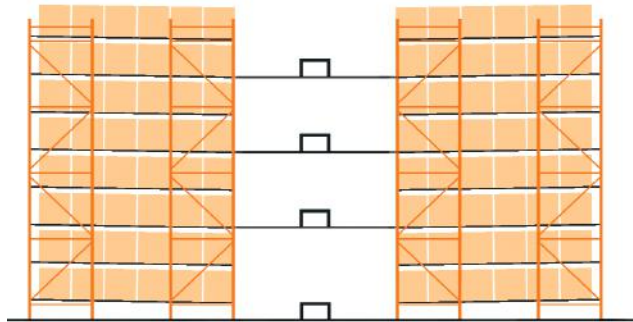
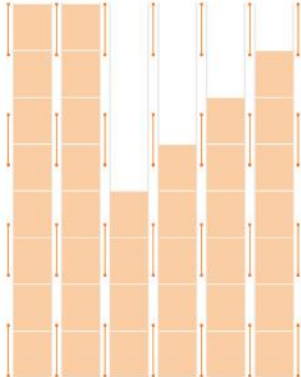

Typical FIFO Installation with center conveyor



Easily Incorporated into complex conveyor distribution systems.

High Density Storage

By converting aisle space into storage space maximum cube utilization is achieved. Savings in land, building construction, energy cost etc. can justify the system. 60% savings of floor space is typical.

First In - First Out

Essential for date sensitive such as Just In Time operations and perishable materials.

Reduced Manpower/Greater Productivity

Products are moved at a controlled speed by the pull of gravity. A system can save human manpower by 75%.

Reduced Traffic

Each stage eliminates product handling and aisle traffic compared to conventional selective storage systems.

Product Segregation

Similar products can be stored in individual lanes greatly reducing shipping errors from product picking or storage errors.

Excellent for Staging

Individual lanes can be used to stage truck loads or order picks either for loading or unloading.

Reduced Equipment and Energy Consumption

With reduced aisle traffic, fewer lift trucks are required (up to 1/3 less). In freezer or cooler storage facilities increased storage density and reduced traffic result in energy savings.

Reduced product damage

Reduces handling and aisle traffic resulting in less product damage and inventory loss.

CANTILEVER RACKING

Designed to handle a wide variety of products without front upright interference. Unrestrained front access for long and irregular shaped products. Products rest on flat or tapered arms for easy loading. The columns act as backstops and flue space for water penetration. Lift truck forks have easy entry for un-palletized loads. Base legs provide stability and keep the product off the floor. All posts are punched to accept arms on both sides.



Cant-Rack roofs or buildings not only provide storage but shelter for products and customers. The roof and walls are constructed of wood or steel trusses and panels. Complete open or closed buildings can be constructed in weeks. Contact your NAS representative for complete planning and CAD drawings for your specific requirements.

CANTILEVER RACKING COMPONENTS

NAS offers four types of Cantilever Rack to meet your specific requirements

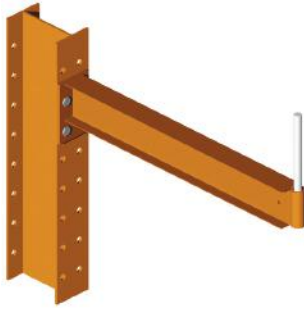

Cant-Bolt-Rack

High tensile structural steel components for added strength and better protection from damage, abuse or impact. Most components can be repaired on site if damaged. Bolted arms are designed to simply bolt on both sides of the column to allow easy conversion from single to double-sided units. Arms are adjustable on 4" centers. The one piece "I" beam is economical without reducing capacity.

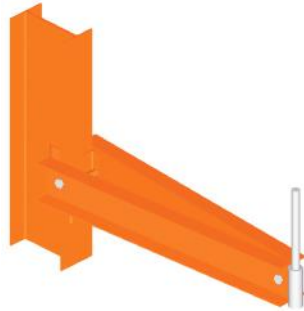

Cant-Clamp-Rack

Same heavy gauge structural components as the Cant-Bolt-Rack. The unique clamp design offers infinite arm adjustability to maximize storage space under changing conditions. Welded base arm and no column holes increase capacity.

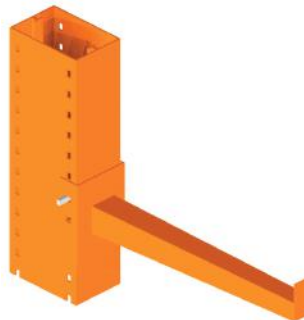

Cant-Clip-Rack

Medium Duty Cant-Rack manufactured from steel plate for specific applications. Cant-Arms are clipped to the column with 4" adjustability. Shelf panels are available to handle small parts. Economical up to 12' height. A wide range of arms and accessories are available.



Cant-Bar-Rack

Uses standard rack components for light duty capacity. Most economical for light loads. Maximum arm length of 24". Adjustable on 3" centers.

Accessories

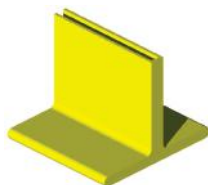

Plastic End Caps



Pole Sockets
Complete With Chain



Sign Holders



EASYUP 7000 LONG-SPAN SHELVING

NAS EASYUP 7000 Shelving designed for hand-loaded bulk storage with open accessibility from all sides. Available with economical particle board or painted steel shelves in almost any configuration. EASYUP 7000 is ideally suited for Mezzanine systems.

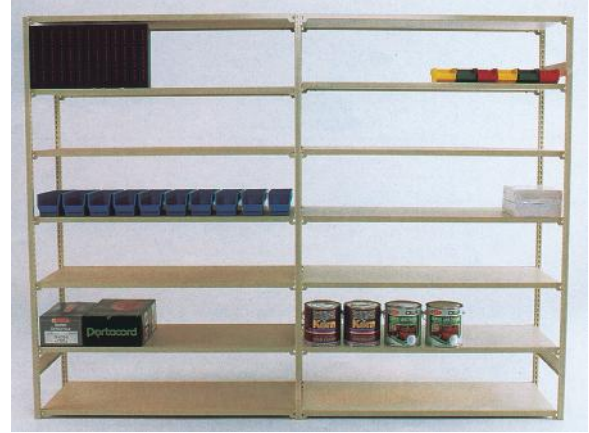

EASYUP 5000 SHELVING

NAS EASYUP 5000 Shelving combines the clean look of Office Shelving with the strength of Warehouse Shelving and economy of Commercial Shelving. It is a multi-purpose storage system, offering a wide range of shelf sizes in particle board and steel shelves.

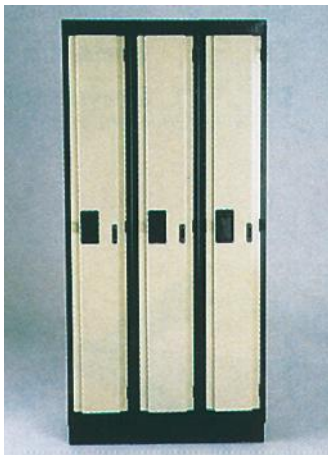

INDUSTRIAL AND INSTITUTIONAL LOCKERS

Strong - Silent - Secure - Maintenance Free

GSS LOCKERS have a full width double pan box door closing on a 5/8" closure strike, the full height of the door. The door is hung on a 16 gauge continuous one-piece right hand hinge and frame. All parts

are coated with abrasion resistant Polymer Powder.

MODULAR DRAWER SYSTEMS

Full Extension Drawers in Drawer Cabinets or Shelving provide optimum storage for valuable tools and parts saving time and space. Existing shelving systems can be fitted with Full Extension Drawers attaining high density storage.



KWIKERECT 1000 BOLTED SHELVING

KWIKERECT industrial and commercial shelving offers strength and durability, ideal for warehouses and stockrooms.



NORTH AMERICAN STEEL

300 Hopkins Street
Whitby, Ontario L1N 2B9

Phone: (905) 668-3300
Email: sales@naseco.ca

Fax: (905) 668-5477
Web page: www.naseco.ca

NORTH AMERICAN STORAGE

2103 - 7th Street
Nisku, Alberta T9E 7Y3

Phone: (780) 955-2444
Email: sales@naseco.com

Fax: (780) 955-3463
Web page: www.naseco.ca